

Regeneration Process without Losses

Emission reduction by closed-loop technology

ReiCat is the leading company for Gas Purification and Gas Recycling.

Decades of experience behind us contributed to developing and producing equipment to efficiently remove all impurities and moisture from Hydrogen in the Green H₂ and the Industrial H₂ markets.

Internal blower

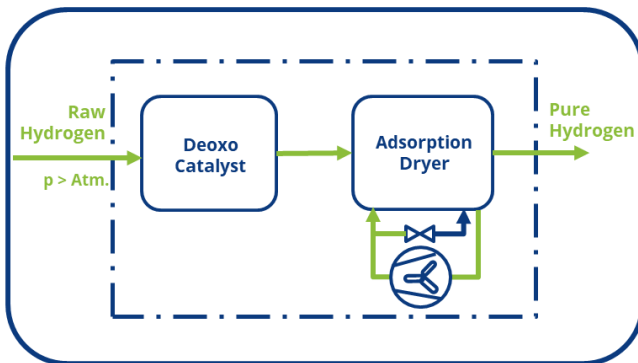

Your application

Green H₂ P-t-G
Wind farm
Solar farm
Renewable

ReiCat Advantages

Start/stop operation
no H₂ stream needed
marginal H₂ losses
energy efficiency

Regulator

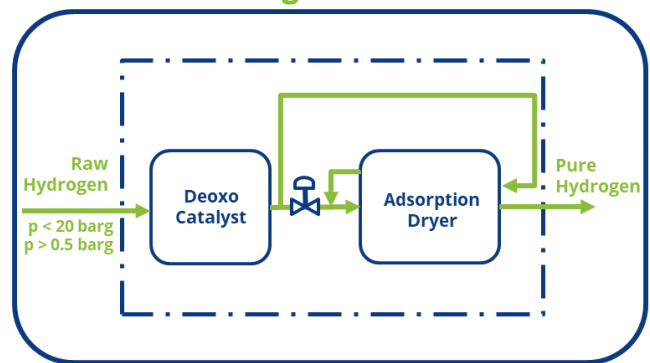

Your application

Chemical Industry
Steel industry
Nuclear plants
24/7 operation

ReiCat Advantages

Zero H₂ losses
no emissions
no rotating equipment
extra H₂ purity

Compressor on-site —/ Altern. booster - -

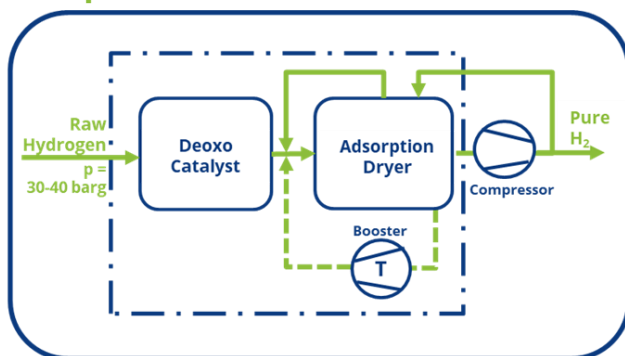

Your application

Green H₂ P-t-G
Wind farm

ReiCat Advantages

Zero H₂ losses
no emissions

Suction side on-site compressor

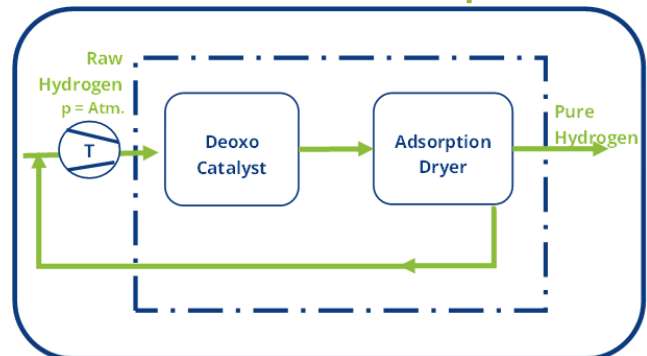

Your application

Green H₂ P-t-G
Wind farm
Solar farm
Renewable

ReiCat Advantages

Zero H₂ losses
no emissions
no extra rotating eq.
up to 6.0
H₂ purity possible

Information is subject to customer operating conditions.